

## THYRATRON TDI4-100K/75

Copper arc thyatron TDI4-100k/75 is a three-gap deuterium or hydrogen-filled thyatron with metal-ceramic envelope. The tube is suitable for use as a switch for either capacitor discharge service with pulse duration from fractions of microseconds to milliseconds or as an electronic crowbar, at peak voltages from a few kilovolts to 85 kilovolts and peak currents up to 150 kiloamperes. The switch incorporates a semiconductor ignitor and high capacity reservoirs to provide extended operational life. Patented dielectric coating protects the envelope against damage in cases when anode reverse voltage increases for up to 100 % value of the forward voltage. The tube has internal shield to minimize X-Ray emission from the region of the anode. Upon special order hollow anode thyatrons (TDI4-100k/75H), capable of conducting a high reverse current and with air or liquid cooling (water, oil) are available.

Design of the thyatron is protected by Russian Federation patents № 1792207, 1807798, 2300157, 2418339, International Patents PCT/RU2005/000298, PCT/RU2011/000038 and US Patent No.7,825,595 B2.

### SPECIFICATIONS

#### ABSOLUTE RATINGS (Maximums, Non-Simultaneous)

Epy, Peak Forward Anode Voltage <sup>(Notes 1,2,3)</sup>	2-85 kV
Ib, Peak Forward Anode Current	150 kA
epx, Peak Reverse Anode Voltage <sup>(Note 4)</sup>	8 kV
Epy, Min., Minimum Anode Supply Voltage	3 kV
tr, Maximum Anode Current Rise Rate <sup>(Note 5)</sup>	$1 \times 10^{12}$ a/s
ibx, Peak Reverse Anode Current <sup>(Note 6)</sup>	10% Ib
Prr, Pulse Repetition Rate	300 Hz
Ib, Switched energy per shot	20 000 J
Ip, RMS Average Current <sup>(Notes 7,8)</sup>	700 Aac
Pb, Anode Dissipation Factor (V x A x pps) <sup>(Notes 7,8)</sup>	$70 \times 10^9$
td, Anode Delay Time	≤500 ns
Time Jitter <sup>(Note 9)</sup>	<3 ns

NB: Operation of the thyatron when two or more parameters are exceeded simultaneously may be permitted only upon agreement with the Manufacturer.

#### A TYPICAL OPERATING CONDITION

epy, Peak Forward Anode Voltage	75 kV
ib, Peak Forward Anode Current	50 kA
tp, Anode Current Pulse Duration	5 μs
Prr, Pulse Repetition Rate	0.1...20 Hz

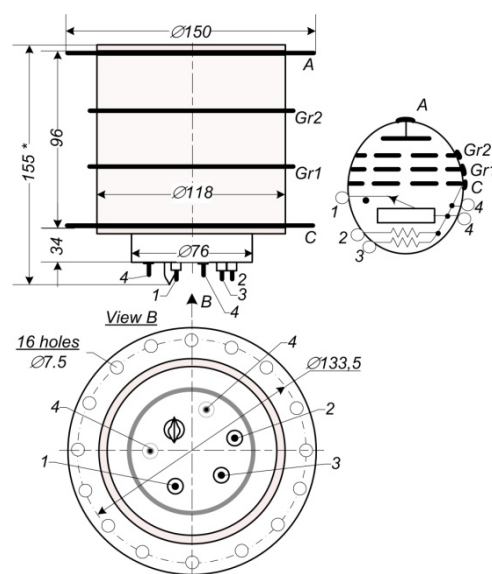
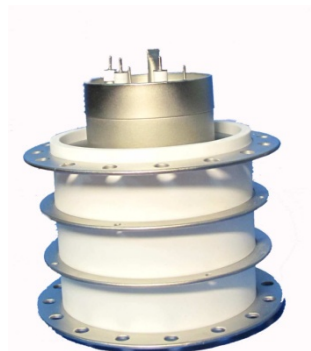

#### TUBE SCHEMATIC & BOTTOM VIEW

- A - Anode;
- Gr - Gradient grid;
- C - Cathode, heater, igniter terminal (+);
- 1 - Trigger negative pulse;
- 2 - Heater R (cold Rres ~1Ω);
- 3 - Heater G (cold Rg ~1Ω);
- 4 - cathode terminals (for driver common only).

### GENERAL ELECTRIC DATA AND TRIGGERING REQUIREMENTS

	MIN	MAX
Er, Reservoir Heater Voltage, Nominal (Vac)	3	7.0
Ir, Nom. Reservoir Heater Current	2.5	-
Er, Getter Heater Voltage, Nominal (Vac)	3	7.0
Ir, Nom. Getter Heater Current	2.5	-
tk, Tube Warm-Up Time (Minimum Minutes)	5	-
Peak Open Circuit Trigger (Ignitor) Voltage (kV)	4	6
Peak Trigger current Amplitude (A)	70	120
Trigger current Pulse Width ( $\mu$ s)	2	5

### NOTES:

<sup>1)</sup> The thyatron may be operated in air at up to 40 kV. Some of the more important derating factors that determine the safe operating voltage in air are the cleanliness of the tube's ceramic insulators, the rate of rise of anode voltage, the dwell time at the operating peak anode voltage, the pulse repetition rate, and ambient pressure, temperature, humidity and contaminant level. This tube may also be operated while immersed in an insulating gas or liquid.

<sup>2)</sup> The dwell time at the peak anode voltage should be minimized in order to minimize pre-firing. For operation at the rated epy, the dwell time must not exceed 1 millisecond.

<sup>3)</sup> After thyatron anode current stops flowing and before voltage is reapplied to the anode, the anode voltage must stay between -100 and -5000 volts for at least 200  $\mu$ s to allow the gas to deionize.

<sup>4)</sup> The reverse anode voltage shown applies for a previously nonconducting tube. Exclusive only of a spike not longer than 25 nanoseconds, the peak reverse anode voltage must not exceed 1 kilovolt during the first 50 microseconds after conduction.

<sup>5)</sup> Rate of rise depends upon the external circuit.

<sup>6)</sup> **For ringing discharge with reverse current up to 95%lb we recommend to use hollow anode modification TDI4-100k/75H.** TDI4-100k/75 thyatron is not designed to conduct current in the reverse direction. The tube will have a tendency to cut-off conduction in the reverse direction but may not be able to stop reverse conduction if the reverse voltage across the thyatron is high enough. In the case where there is conduction in the reverse direction, the absolute value of the reverse peak current must be limited to no more than 10% of the peak value of the previous positive half cycle of the thyatron current waveform. At  $P_b > 3 \cdot 10^9$  and  $RMS > 80$  the thyatron must be used in burst mode only. Durations of the bursts and pause must be agreed with the Manufacturer.

<sup>7)</sup> Forced air or liquid immersion cooling should always be used in any situation where cooling by natural convection is insufficient to keep the temperature of the tube's envelope below 100°C. Typically, a room temperature air flow of 50 to 150 cfm directed into the anode cup and cathode will be sufficient. When the tube is cooled by immersion in a force-circulated liquid coolant, the anode dissipation factor may be tripled provided that the envelope temperature does not exceed 100°C.

<sup>8)</sup> Delay time, delay time drift and time jitter may be simultaneously minimized by using specially designed switch TDI3-100k/75(H).

<sup>9)</sup> All data and specifications are subject to change without notice.

### LIFETIME:

Service time expectancy varies according to the application. However provided that certain precautions are observed for the typical operating conditions lifetime should be not less than  $1 \times 10^6$  Coulombs of total charge transfer.

In order to minimize magnetic field effects we recommend a coaxial type mounting of the thyatrons.